

RELEASE

DATE:

COMPANY:

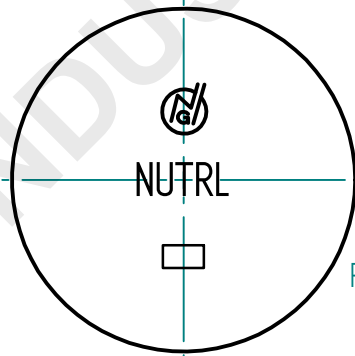
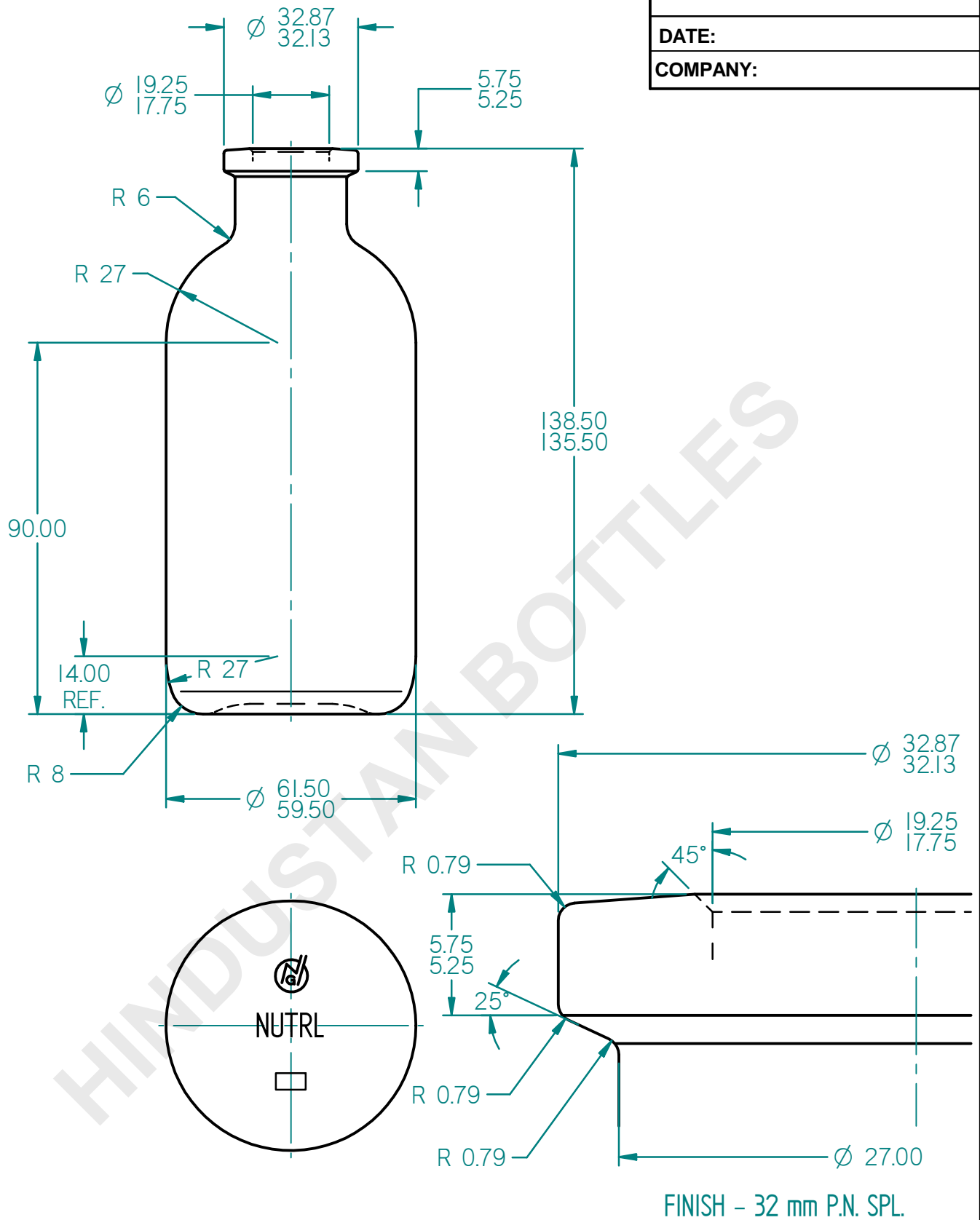

FINISH - 32 mm P.N. SPL.

Protective note ISO 16016 observed

GENERAL TOLERANCES DIN 6129-1 (DIMENSIONS WITHOUT TOLERANCES ARE FOR REFERENCE ONLY)				FINISH: 32 mm P.N. SPL.		O'FLOW CAPACITY: 233.0 - 247.0 ml		ARTICLE NO.:			
				FINISH DWG: NA		WEIGHT: 180 g Approx		5156191100			
				FINISH MOLD NO: 155		TYPE OF GLASS: I COLOUR: FLINT					
				DATE	NAME	200 ml P/N W/H					
				DRAWN	22/11/2013					Paresh	
				CHECKED	22/11/2013					H.B.P.	
				SCALE	1 : 1.33 , 4 : 1						
				GERRESHEIMER NEUTRAL GLASS & ALLIED INDS. PVT. LTD. MUMBAI / KOSAMBA			MOLD NO.:	DRAWING NO.:	REVISION	SHEET	FORMAT
							153	B 6191		0	1 OF 1
REV.	CHANGE	DATE	NAME	FILE: 200 ml PN WH.dft							